

SPECIFICATIONS

SW310WA01 12¼" alu-cone subwoofer, 8 ohm

SW310WA01 is a woofer designed for dedicated subwoofer applications. It works equally well for high-end hi-fi, high quality home theater systems, and top multimedia setups.

The extremely stiff aluminium cone, the long linear throw, exaggerated ventilation, and the special dynamic linearization short circuiting rings together makes up for an unusually linear and low-distortion woofer. Even at very high signal levels, the unit behaves controlled and without distortion.

Due to low mechanical losses SW310WA01 masters equally well low level details and extreme dynamic requirements.



FEATURES

- Extremely rigid aluminium cone to ensure piston motion at high levels and for better heat transfer at high continuous power levels
- Die cast alu chassis with optimal ventilation and increased stroke
- Vented cone neck for reduced distortion and compression
- Vented chassis for lower air flow speed reducing audible distortion
- Heavy-duty black fiber glass voice coil bobbin to reduce mechanical losses resulting in better dynamic performance and low-level details
- Large motor system with 2" voice coil diameter and 145mm magnet for better control and efficiency
- Black-anodized magnet structure steel parts for increased heat dissipation and power handling
- Two built-in alu field stabilizing rings for reduced high-level distortion (see drawing)
- Long linear stroke motor for reduced distortion at high levels
- Linear suspension with specially designed CONEX damper (spider) for long durability under extreme operating conditions
- 4-layer voice coil for increased control and better small-cabinet performance

NOMINAL SPECIFICATIONS

Notes	Parameter	Before burn-in	After burn-in	Unit
	Nominal size		12¼	[inch.]
	Nominal impedance		8	[ohm]
	Recommended max. upper frequency limit		300	[Hz]
1, 3	Sensitivity, 2.83V/1m (calculated from T/S parameters)		87	[dB]
2	Power handling, short term, IEC 268-5, no additional filtering			[W]
2	Power handling, long term, IEC 268-5, no additional filtering			[W]
2	Power handling, continuous, IEC 268-5, no additional filtering		250	[W]
	Effective radiating area, S _d		513	[cm ²]
3, 6	Resonance frequency (free air, no baffle), F _s	28.5		[Hz]
	Moving mass, incl. air (free air, no baffle), M _{ms}		180	[g]
3	Force factor, BxI		18.1	[N/A]
3, 6	Suspension compliance, C _{ms}	0.173		[mm/N]
3, 6	Equivalent air volume, V _{as}	65		[lit.]
3, 6	Mechanical Q, Q _{ms}	11.5		[-]
3, 6	Electrical Q, Q _{es}	0.62		[-]
3, 6	Total Q, Q _{ts}	0.59		[-]
4	Voice coil resistance, R _{DC}		6.3	[ohm]
5	Voice coil inductance, L _e (measured at 1 kHz)		2.5	[mH]
	Voice coil inside diameter		51	[mm]
	Voice coil winding height		31	[mm]
	Air gap height		8	[mm]
	Magnet weight		2.7	[kg]
	Total unit net weight excl. packaging		6.5	[kg]
3, 5	K _{rm}		12.8	[mohm]
3, 5	E _{rm}		0.72	[-]
3, 5	K _{xm}		18.7	[mH]
3, 5	E _{xm}		0.74	[-]

Note 1 Measured in infinite baffle.

Note 2 Tested in free air (no cabinet).

Note 3 Measured using a semi-constant current source, nominal level 2 mA.

Note 4 Measured at 20 deg. C

Note 5 It is generally a rough simplification to assume that loudspeaker transducer voice coils exhibit the characteristics of an inductor. Instead it is a far more accurate approach to use the more advanced model often referred to as the "Wright empirical model", also used in LEAP-4 as the TSL model (www.linearx.com), involving parameters K_{rm}, E_{rm}, K_{xm}, and E_{xm}. This more accurate transducer model is described in a technical paper [here at our web site](#).

Note 6 After burn-in specifications are measured 12 hours after exiting the transducer by a 20 Hz sine wave for 2 hours at level 20 VRMS. The unit is not burned in before shipping.

SPECIFICATIONS

SW310WA01 12¼" alu-cone subwoofer, 8 ohm

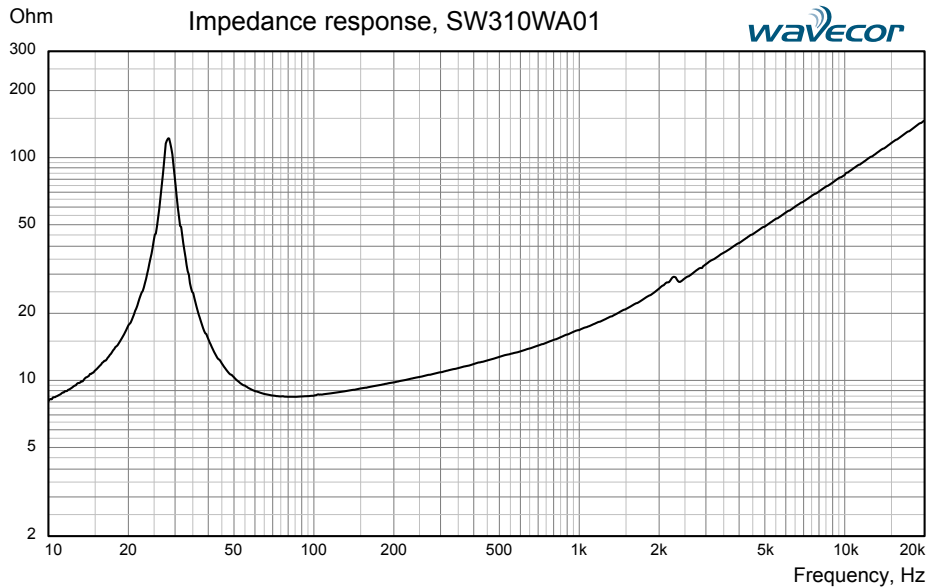

Measuring conditions, impedance
 Driver mounting: Free air, no baffle,
 back side open (no cabinet)
 Input signal: Stepped sine wave, semi-
 current-drive, nominal current 2 mA
 Smoothing: None

OUTLINE DRAWING (nominal dimensions, mm)

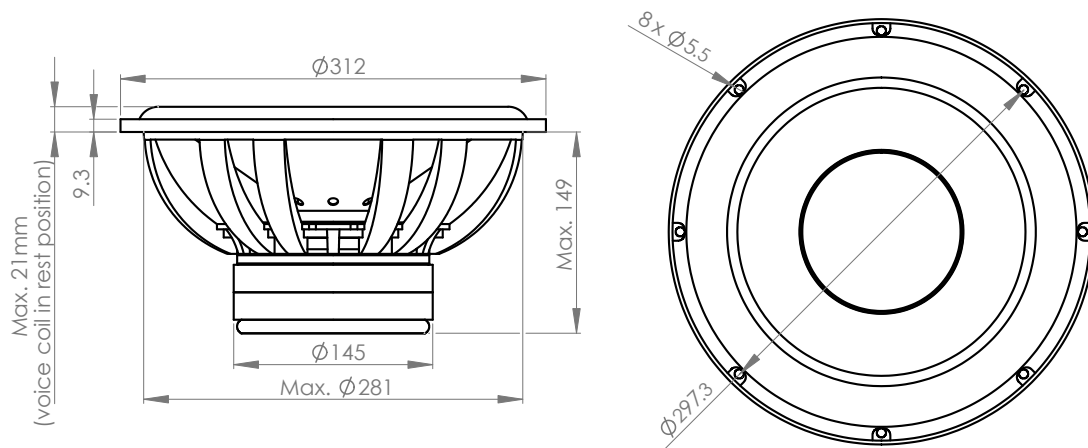

PACKAGING AND ORDERING INFORMATION

Part no. SW310WA01-01	Individual packaging (one piece per box)
-----------------------	--